

# NOVATECH INSTRUMENTS, INC.

## INSTRUCTION MANUAL

### **Model 409B 171 MHz 4-Channel Signal Generator**



## **Model 409B**

### Table of Contents

Section	Page	Contents
1.0 .....	2 .....	Description
2.0 .....	2 .....	Specifications
3.0 .....	2 .....	Hardware Installation
4.0 .....	5 .....	Operation
5.0 .....	6 .....	Theory of Operation
6.0 .....	8 .....	Performance Test
7.0 .....	9 .....	Calibration
8.0 .....	10 .....	Appendix A: Table Mode Details
9.0 .....	12 .....	Appendix B: External Reference
-- .....	13 .....	Warranty

## 1.0 DESCRIPTION

1.1 The Model 409B is a four-channel **D**irect **D**igital **S**ynthesizer (DDS) in a small table top case with RS232 serial control. The 409B provides four independent, phase-synchronous sine wave (consult factory for LVCMOS) output signals, which can be set from 0.0 Hz (DC) to 171 MHz in 0.1 Hz steps when using the internal VCTCXO clock.

1.2 The 409B can also be used with an External Clock input. An on-board programmable frequency multiplier generates the master clock allowing user configured frequency ranges. The multiplier can be disabled for direct inputs up to 500 MHz for optimum phase noise performance. When used with the same external clock source, multiple 409B are phase synchronous.

1.3 The /R option converts the External Clock input to a 10.00 MHz reference input. Using the same topology as our locking programmable oscillator modules, this options allows locking to and tracking of an external 10.00 MHz, with no binary round-off errors. When this option is installed the accuracy and stability of the output are equal to those of the reference.

## 2.0 SPECIFICATIONS

### 2.1 OUTPUTS

TYPES: Four Sine simultaneously (four independent, phase-synchronous outputs.)

IMPEDANCE: Sine: 50  $\Omega$ ; LVCMOS: 50  $\Omega$ .

RANGE: 0.0 Hz to 171 MHz in 0.1 Hz steps (Sine out, int. clock).

SINE AMPLITUDE: approximately 1  $V_{pp}$  (+4dBm) into 50 $\Omega$ . Programmable from 0/1024 to 1023/1024 of Full Scale (10-bits), or by scale factors of 1/2, 1/4, or 1/8.

PHASE: Each channel 14-bits programmable (0.022 $^\circ$ ).

FLATNESS:  $\pm 3$ dB from 1 kHz to 150 MHz referenced to amplitude at 35 MHz, full scale.

### 2.2 LVCMOS AMPLITUDE

$V_{oh} \geq 2.4V$  and  $V_{ol} \leq 0.4V$  when series terminated. Rise and fall times <1.5ns. (>1 MHz, <125 MHz) (consult factory for LVCMOS)

### 2.3 CONTROL

Output frequencies, amplitudes (10-bits) and phases (14-bits) are controlled by an RS232 serial port at 19.2kbaud,

or direct connection to the DDS generator. All settings (except table mode data) can be saved in non-volatile (EEPROM) memory via the RS232 port.

### 2.4 ACCURACY AND STABILITY

Accuracy:  $< \pm 1.5$ ppm at 10 to 40 $^\circ C$ . Stable to an additional  $\pm 1$ ppm per year, 18 to 28 $^\circ C$ . (Internal Clock)

### 2.5 EXTERNAL CLOCK IN

LEVEL: 0.2 to 0.5 Vrms Sine or Square Wave. 50  $\Omega$ .

FREQUENCY: 10 MHz to 125 MHz with multiplier of 4 to 20 enabled. Direct input of 1 MHz to 500 MHz.

/R Option: 10.00 MHz,  $\pm 5$ ppm. Automatically detected. Internal clock is locked to and tracks this value.

### 2.6 SPECTRAL PURITY (Typ. 50 $\Omega$ load, internal clock, full-scale output)

Phase Noise: <-120dBc, 10kHz offset, 10 MHz out.

Spurious: <-60dBc below 10 MHz (typ. 300MHz span)

<-60dBc below 40 MHz

<-55dBc below 80 MHz

<-50dBc below 160 MHz

Harmonic: <-65dBc below 1 MHz

<-55dBc below 20 MHz

<-45dBc below 80 MHz

<-35dBc below 160 MHz

(channel-channel isolation: <-60dBc)

### 2.7 TABLE MODE

On-board 4Mb static ram holds up to 32,768 profile points in table mode allowing a different output in 100  $\mu S$  increments.

### 2.8 POWER REQUIREMENTS

+4.5 to +5.5 VDC <1Amp. AC adapter provided.

### 2.9 SIZE

39mm H, 107mm W, 172mm L, not including connectors.

### 2.10 CONNECTORS

BNC for Sine Outputs and EXT CLK IN. DE9 for Serial Control. 2.5mm center positive power receptacle for +5 volts input. AC-adapter provided.

### 2.11 OPTIONS

Model 409B-AC adds two rear-panel SMA connectors for external control of output update and table timing (see AN002). /R Option converts the External Clock In to a 10.00 MHz external reference input (see Appendix B).

### 3.0 HARDWARE INSTALLATION

3.1 **Power Connection.** The required power of +5Volts DC is applied through a 2.5mm center-positive power connector (Switchcraft 712A or equivalent). The Novatech Instruments, Inc. supplied AC-adaptor comes complete with the correct mating connector.

**WARNING:**

*Use of an unregulated source may damage the 409B. Use only the provided AC-adapter or consult Novatech Instruments, Inc. for application assistance if you wish to use another power source.*

3.2 The quality of your power supply affects the performance of the 409B. The supply should be free of ripple and noise (<50mV). Even though extensive filtering is used internal to the 409B, a quiet and well regulated power supply will ensure optimum performance. The supplied AC-adapter has been tested for proper operation.

3.3 **Installation.** To use the 409B, connect your host computer to the 9-pin female RS232 connector on the rear panel of the 409B. If you are using a PC, a 9-pin monitor extension cable used as an RS232 cable will allow direct connection to the 409B without the use of a null modem cable or gender changer. If you are using a different computer, terminal or other control source, please note that the data **TO** the 409B is on pin 3; the data **FROM** the 409B is on pin 2 and the **COMMON** return is on pin 5. Set your host to 19.2 kBaud, 8 bits, 1 stop bit, no parity and no hardware flow control. See Table 2 for Serial Commands.

3.4 A USB to RS232 adapter cable is available for use with computers that do not provide a serial port. Follow the manufacturer's installation instructions when using a USB adapter.

3.5 Commands are not case sensitive. There must be a space after each command except R, CLR, S and QUE. End with any combination of CR, LF or

CRLF. Illegal commands will result in an error code being returned per Table 1.

**Table 1: RS232 Error Codes**

Error Code	Meaning
OK	Good command received
?0	Unrecognized Command
?1	Bad Frequency
?2	Bad AM Command
?3	Input line too long
?4	Bad Phase
?5	Bad Time
?6	Bad Mode
?7	Bad Amp
?8	Bad Constant
?f	Bad Byte

3.6 The "QUE" command returns five hexadecimal strings reflecting the present state of the 409B. See page 7 for an explanation of the values that make up these strings. Note that the frequency settings will be scaled as discussed below if an external clock is used.

3.7 The "B" command can cause erroneous operation and must be used with care. Contact Novatech Instruments, Inc. for application assistance if you wish to use this command. Detailed knowledge of the operation of the Analog Devices AD9959 DDS generator is required.

**NOTE:**

*The program SOF8 is supplied with the 409B. This program provides a graphical interface for all the serial commands, allowing simple control of the 409B.*

3.8 **Internal Clock.** If you plan to use the 409B internal clock, which is the default setup mode, no action is required. If the 409B was previously set to use the external clock, send the serial command "C i" to reselect the internal clock. If you wish to maintain this setting, use the save command "S".

3.9 **External Clock.** If you are providing your own clock source, send the serial command "C e". Apply your clock to the External Clock Input BNC on the rear panel. Note that phase noise and stability

**Table 2: Serial Commands**

<b>RS232 Command</b>	<b>Function</b>
Fn xxx.xxxxxxxx	Set Frequency of output “n” in MHz to nearest 0.1 Hz. Decimal point required. Set to 0.00 to turn off a channel. n=0, 1, 2, 3. Maximum setting: 171.1276031 MHz. Single tone mode.
Pn N	Set Phase of output “n”. N is an integer from 0 to 16383. Phase is set to $N*360^\circ/16384$ or $N*\pi/8192$ radians. Sets the relative phase of the frequency output depending upon the value of n=0, 1, 2, 3. Single tone mode.
Vn N	Set voltage level of output “n”. In default, the amplitude is set to the maximum: approximately $1V_{pp}$ (+4dBm) into $50\Omega$ . N can range from 0 (off) to 1023 (no decimal point allowed). Voltage level is scaled by N/1023. n=0, 1, 2, 3 to set the amplitude on frequency 0, 1, 2 or 3. If $N \geq 1024$ , the scaling is turned off and the selected output is set to full scale.
E x	Serial echo control. x=D for Echo <b>Disable</b> , x=E for Echo <b>Enable</b>
C x	Select clock source. x=E for <b>External</b> clock, x=I for <b>Internal</b> Clock. May require adjustment of Kp and the addition of external filtering of output. (Do not use this command if the /R option is installed)
R	Reset. This command resets the 409B. EEPROM data is preserved and, if valid, is used upon restart. This is the same as cycling power.
CLR	Clear. This command clears the EEPROM valid flag and restores all factory default values.
A x	x=E for LVC MOS <b>Enable</b> , x=D for LVC MOS <b>Disable</b> . (consult factory for LVC MOS)
S	Saves current state into EEPROM and sets valid flag. State used as default upon next power up or reset. Use the “CLR” command to return to default values.
QUE	Return present frequency, phase and status. Returns a character string of all internal settings.
M N	Mode command. Mode ‘0’ is single tone on all channels (default). If N=a, then the phase is automatically cleared during each command; if N=n, then the phase is not cleared (default). See Section 4.0 for details. See appendix for table mode.
Vs N	Set the output Voltage scaling factor. N=1 for full scale, N=2 for one-half scale, N=4 for one-quarter scale and N=8 for one-eighth scale. All channels are scaled equally.
Kp aa	Set PLL reference multiplier constant. Must be one Hexadecimal byte as two characters. Legal values are 1 (bypass PLL) and 4 to 20 ( $01_h$ , $04_h$ to $14_h$ ). Values of Kp times clock frequency must not be between 160MHz and 255MHz (for internal clock, this disallows $5 \leq Kp \leq 9$ ). (see paragraph 4.12) Not used with /R option.
I x	Set the I/O update pulse method. If x=a, then an I/O update is issued at the end of each serial command (default). If x=m, then a manual I/O update pulse is sent by a subsequent ‘I p’ command. (see section 4.0 for details)
<b>B aa[bb[cc[dd[ee[ff[gg]]]]]]]</b>	This <b>Byte</b> command allows each register in the DDS chip to be set. Different registers require a various number of bytes to be written depending upon the function. Please consult the manual for details. Note that it is possible to set the DDS chip into a non-functional mode, requiring a power cycle to recover. All values are in hexadecimal and no error checking, other than correct format, is performed.

are dependent upon your supplied clock. See specifications for signal levels required and acceptable frequency range. If you wish to maintain this setting, use the save command "S".

3.10 The external clock can also be used with Kp=1 for direct connection to the DDS generator. With Kp=1, the PLL multiplier is disabled. Use this direct input, up to 500 MHz, for optimum phase noise performance.

**NOTE:**

*When using an external clock, frequency scaling of the "F" command may be required. Please see Operation, Section 4, for details. If your unit has the /R option installed, see Appendix B.*

3.11 **Signal Outputs.** There are four signal outputs on the 409B labelled 0 to 3 on the front panel BNCs. These correspond to channels F0 through F3, and other commands. Simply connect your 50Ω application cable to appropriate output.

3.12 **Mounting.** An optional 1U rack adapter is available for mounting up to four 409B into a rack panel. Please consult factory.

## 4.0 Operation

4.1 **Power on reset.** After power is applied, the 409B takes approximately 500ms to initialize. Commands sent during this time will be ignored or may cause erroneous operation.

4.2 Specifications are met within approximately 15 minutes of power up.

4.3 After the 409B has been installed in the customer application system, all that is required for operation is to send the appropriate serial commands per Table 2.

4.4 The user host computer software must properly format the serial commands. Incorrect formatting will result in an error code being returned. See Table 1 for a list of error codes.

4.5 For maximum interface speed, it is suggested that Echoing be disabled by the "E d" command. This will allow the host to send characters at a faster

rate. Note that no flow control is provided. Depending upon your host, the 409B may not be able to keep up with serial characters. The 409B will respond with an "OK" for a correctly received data command. You will have to verify correct operation at your host rate.

4.6 A special baud rate command is available if you wish to set a different baud rate. The value set by this command is volatile and not saved in EEPROM. Upon power up, reset or clear, the 409B defaults to 19.2kBaud.

Kb 78	;9.6kBaud
Kb 3c	;19.2kBaud
Kb 1e	;38.4kBaud
Kb 14	;57.6kBaud
Kb 0a	;115.2kBaud

4.7 If you are using an external clock, the value sent to the 409B in the "Fn" command must be scaled. The output frequency of the 409B when used with an external clock is given by:

$$F_{out} = (F_{command}) * (K_{pe} * F_{ext\ clk}) / (K_{pi} * F_{int\ clk})$$

Where  $K_{pe}$  is the value of Kp set by the customer, and  $K_{pi}$  is the internal default Kp (0x0f).

4.8 The nominal Internal Clock has a value of 28,633,115.306666666 Hz ( $2^{32}/150$ ). Best performance is obtained when the External Clock input times the Reference PLL multiplier (Kp) is close to the default value (429.4967296 MHz, max: 500 MHz), as the on-board filters are optimized for that range.

4.9 For an example of scaling, suppose an external clock of 10.000 MHz is used and an output of 1.544 MHz is desired (Kp=15):

$$F_{command} = (1.544) * (15 * 28,633,115.306666667) / (15 * 10,000,000) = 4.4209530$$

4.10 The command then sent to the 409B for the 1.544 MHz output, with a 10 MHz external clock, will be (assuming Kp is unchanged):

Fn 4.4209530

where 'n' is your selected channel

**NOTE:**

*You must account for your clock frequency error and calculation roundoff when using an external clock. Some hand calculators may not have enough digits to match the resolution of the 409B. See Appendix B if your unit has the /R option installed.*

4.11 Beginning with Software Revision 2.1, it is possible to control the internal range bit on the DDS ASIC.

4.12 For normal operation the Kp command is unmodified. However, if it is desired that the clock multiplier gain bit be set HIGH (for Kp\*[Ext Clk Freq] from 255 and 500 MHz), add hexadecimal 0x80 to the Kp value to be set. For the bit to be forced LOW (100 to 160 MHz), add hexadecimal 0x40 to the Kp value to be set.

4.13 Since the resolution of the 409B is 32-bits, the typical fractional frequency error ( $\Delta f/f$ ) for output frequencies in the MHz range will be less than 0.1ppm, even when exact values are not possible.

**Typical  $\Delta f/f$  for External Clock of 10.0MHz**

Kp	Desired Fout	Command	$\Delta f/f$
15	1.544MHz	Fn 4.4209530	$2.19 \times 10^{-8}$
20	1.544MHz	Fn 3.3157148	$1.43 \times 10^{-8}$
15	2.048MHz	Fn 5.8640620	$1.45 \times 10^{-8}$
20	2.048MHz	Fn 4.3980465	$2.02 \times 10^{-8}$

**NOTE:**

*The "B" command can be used to test AD9959 DDS chip programming as it allows access to all internal registers. While not a real-time simulation, each "B" command functions as an input by putting a data byte directly into the AD9959 via an SPI port, and then pulses the IOUD line. This is the similar to a procedure that a customer control circuit might perform. Consult the Analog Devices AD9959 data sheet for detailed information.*

4.14 Phase relationships are maintained by appropriate use of the "M" and "I" commands. The "M" command has special modes "M a" and "M n". "M a" means automatically clear phase at the end of each command. This will clear the phase register each time any command is performed. This is important when all outputs must be phase aligned. However, it will cause a phase jump in the output.

4.15 The "M n" command turns off the automatic clearing of the phase register. This is the default mode. In this mode, the phase register is left intact when a command is performed. Use this mode if you want frequency changes to remain phase synchronous, with no phase discontinuities.

4.16 Further control of phase relationships and timing of command execution can be exercised by using the "I m", "I a" and "I p" commands. The default mode is "I a" in which a command is parsed and executed immediately following the end of the serial input sequence. In the "I m" mode, an update pulse will not be sent to the DDS chip until an "I p" command is sent. This is useful when it is important to change all the outputs to new values simultaneously.

4.17 For applications which require precise amplitude matching between the channels, the recommended method is to use the "Vn N" command to adjust the channels to match the other. This command provides 10-bits of adjustment range.

## 5.0 Theory of Operation

5.1 Please refer to the simplified System Block Diagram in Figure 3 for the following discussion.

5.2 At every cycle of the 409B master clock, the 32-bit DDS integrated circuit increments the phase of an internal register by a value determined by the frequency setting loaded into the on-chip registers. This digital phase value is converted on-chip to a sinusoidal amplitude level and delivered to on-chip 10-bit digital-to-analog converters. The analog signals from these converters are filtered by differential 7th-order elliptical low pass filters, amplified and sent to the BNC receptacles.

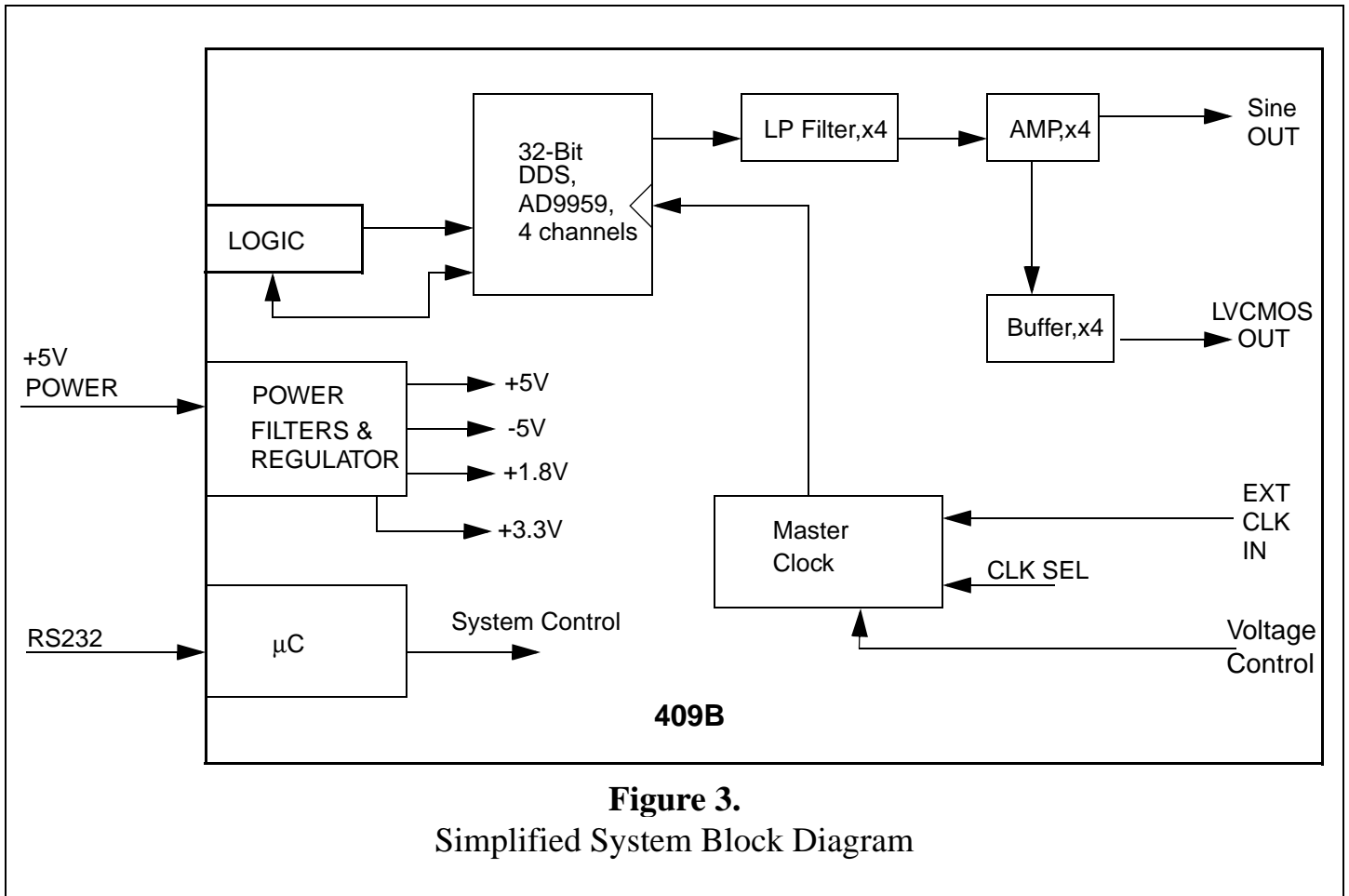

"Que" command output (all values are hexadecimal) values:

```
05F5E100 0000 03ff 0000 00000000 00000000 000301
05F5E100 1000 03ff 0000 00000000 00000000 000301
05F5E100 0000 03ff 0000 00000000 00000000 000301
05F5E100 1000 03ff 0000 00000000 00000000 000301
80 BC0000 0000 6102 21
```

**Description:**

Line 1: "05F5E100", frequency in 0.1Hz steps per LSB; "0000", phase setting; "03ff", amplitude setting (default is scaling off, so output is full-scale); "0000", linear ramp rate; "00000000", rising delta frequency; "00000000", falling delta frequency, "000301", channel function register.

The last line gives the status of AD9959 registers and internal software registers: "80", channel select register (CSR); "BC0000", function register 1 (FR1); "0000", function register 2 (FR2); "6102", internal µC control registers; "21", software revision as x.y, Rev 2.1 in this example. Consult the Analog Devices AD9959 data sheet for meaning of registers. Each line is terminated by a carriage return/line feed (CRLF) pair.

5.3 The frequency generated by the DDS IC is determined by the 32-bit frequency word loaded into the frequency register on the 409B. The output frequency is given by:

$$F_{out} = F_{setting} * Kp * F_{clock} / 2^{32} \text{ Hz}$$

Where:  $F_{clock} = 28,633,115.306666667 \text{ Hz (int.)}$   
 $F_{setting} = \text{Binary value in DDS IC.}$   
 $(F_{setting} \text{ ranges from } 0 \text{ to } 2^{31}-1)$   
 $Kp = \text{PLL Multiplier (1 or 4 to 20)}$

This reduces to:

$$F_{out} = F_{setting} \text{ MHz}$$

for the internal (default) clock and the default PLL Multiplier ( $Kp=15$ ) settings.

5.4 Since the DDS IC is a sampled data system, the output frequency is limited to a maximum of 1/2 the master clock frequency ( $F_{setting} \leq 2^{31}-1$ ). While it is possible to generate an output near 50% of the clock, the distortion may be unacceptable. Therefore, the output is limited to approximately 40% of the system clock and steep output filters are provided on board: in this case 7th-order elliptical low pass filters.

5.5 If you are using an external clock and a Kp which give a clock substantially lower than the 429.497 MHz default internal clock, you may need to filter the Outputs to obtain acceptable distortion for your application. For best performance, set the corner frequency at 40% or less of your external clock frequency times Kp. The lower your filter as a percentage of your clock frequency, the lower the distortion.

5.6 For example, if you are using a 10 MHz external clock, with the default reference multiplier (Kp) of 15, then the internal clock is 150 MHz. An optimal filter for this frequency would then be approximately 60 MHz (40% of 150 MHz).

## 6.0 PERFORMANCE TEST

6.1 Install the 409B as directed in the Serial Operation part of Section 3. Connect your host controller and operate the 409B per Section 4. The test limits assume a stable environment of 18-28°C.

### NOTE:

*Allow the 409B to warm up for at least 15 minutes before performing any measurements. For best results, the 409B should be verified in its installed environment.*

6.2 See Table 3 for a list of recommended test equipment to perform the following measurements.

**Table 3: Recommended Test Equipment**

<u>Item</u>	<u>Minimum Specification</u>	<u>Recommended</u>
Oscilloscope	300 MHz, 50Ω	Tektronix TDS3032B
50Ω Termination	50Ω, ±1%	Tektronix 011-0049-01
Frequency Counter	180 MHz	HP53132A
Counter Time Base	10 MHz, <±0.1ppm	Novatech Instruments Model 2960AR
External Clock	400 MHz	Novatech Instruments Model 440A

6.3 **Verify Frequency Accuracy.** To verify the frequency of the 409B, set the output sequentially to each value in Table 4. Connect the recommended frequency counter set to 50Ω termination and 1Hz resolution. Verify the limits show in Table 4. Test all channels to verify functionality of all outputs. If you do not use an external reference for the frequency counter, be sure to add the error of your counter to the tolerance. (LSD = **Least Significant Digit** on counter).

**Table 4: Frequency Test Points**

<b>Frequency</b>	<b>Tolerance</b>
100 kHz	±0.15 Hz ±1 LSD
1 MHz	±1.5 Hz ±1 LSD
10 MHz	±15 Hz ±1 LSD



**Table 4: Frequency Test Points**

Frequency	Tolerance
30 MHz	$\pm 45 \text{ Hz} \pm 1 \text{ LSD}$
50 MHz	$\pm 75 \text{ Hz} \pm 1 \text{ LSD}$
100 MHz	$\pm 150 \text{ Hz} \pm 1 \text{ LSD}$
170 MHz	$\pm 255 \text{ Hz} \pm 1 \text{ LSD}$

**6.4 Sine Out Amplitude Verification.** Set the frequency of the 409B to 10 MHz. Connect the 409B to the oscilloscope set for 50 $\Omega$  termination. Set the oscilloscope to measure to amplitude using at least 16 averages. Verify a reading of 1Vpp  $\pm 0.25$ Vpp. Repeat for the other outputs.

**6.5 Level Command Test.** Leave the output frequency set to 10 MHz. Send the commands "Vn 512" to each channel, where "n" is your channel number being tested. Verify that the amplitude on each channel decreases by one-half. Send the "R" command to reset the levels before performing the next tests.

**6.6 Output Flatness Verification.** Verify that the outputs are flat with frequency by performing the following test: Connect the 409B to the oscilloscope set for 50 $\Omega$  termination. Use the same settings as Sine Out Amplitude Verification. Note the voltage reading.

**6.7** Set the 409B to the values of Table 4. Verify that the oscilloscope amplitude reading remains within  $\pm 3$ dB (x1.414 to x0.707) of the value noted in the previous paragraph. (limit upper frequency to 150 MHz)

**6.8** Repeat the output flatness verification test for each output.

**6.9 External Clock Input Verification.** Set the frequency output to 10.000 MHz by sending the command "F0 10.7374182" (scaled per section 4.0). Connect a 400 MHz external clock source via a short coaxial cable to the external clock BNC on the rear panel. Send the command "Kp 01". Send the command "C e" to select the external clock input.

**6.10** Verify an output of 10.0000000 MHz,  $\pm 1$  Hz. You must account for any frequency errors in your external clock source.

**6.11** Return the 409B to normal operation and default values by sending the "CLR" command.

**6.12** This concludes the verification test of the 409B.

## 7.0 CALIBRATION

**7.1** The 409B has two adjustable components: Y2, frequency, and R22, output amplitude. Calibration should be performed only if the 409B fails the performance test or if the unit has been repaired. Routine adjustments are not recommended nor generally required. This procedure assumes that the 409B has failed the performance test or has been repaired.

### WARNING:

*Calibration of the Model 409B requires that the case be opened. Calibration should be performed only by qualified personnel. The internal components are static sensitive.*

**7.2** Access to the adjustments is provided by removing the rear panel fasteners. Remove the two phillips head screws on the rear panel, the power receptacle nut, and the two jack-screws holding the RS232 connector. Tip the rear panel away from the instrument and slide the top cover off. Be careful not to unduly flex the connecting wires.

**7.3** The adjustments shown are set to 1/2 the specification values.

### NOTE:

*Allow the 409B to warm up for at least 15 minutes before performing any adjustments. For optimum performance the 409B should be calibrated in an environment similar to its installation.*

### NOTE:

*If your unit has the /R option installed, the oscillator adjustment is the same, except the location has moved to the adapter board.*

**7.4 Frequency Adjust, Y2.** Set the output of the 409B to 10.0000000 MHz using the command "F0 10.0000000". Connect output of channel 0 to your frequency counter set for 50  $\Omega$  termination.

Adjust Y2 using a non-metallic adjustment tool for 10.000000 MHz,  $\pm 7.5$  Hz.

**NOTE:**

*If your unit has the /R option installed, the access to R22 is blocked by the module. Remove the two screws securing the module and carefully reposition the module to allow access to R22.*

**7.5 Amplitude Adjust, R22.** Connect the output of channel 0 to the oscilloscope set to measure amplitude, with a minimum of 16 averages. Set for 50  $\Omega$  termination. Set the output to 35 MHz by sending the command "F0 35.00000000". Adjust R22 for 1.00 V<sub>pp</sub>  $\pm 0.075$  V<sub>pp</sub>. This completes the calibration of the Model 409B.

## 8.0 Appendix A. Table Mode Details.

8.1 The Model 409B contains on-board static RAM capable of storing up to 32,768 profile points. Each point contains phase, frequency, amplitude and dwell time information. The on-board microcomputer reads this RAM and programs the DDS ASIC per the profile point data. The profile can be set to loop continuously or to hold at the last point, until interrupted by a subsequent command.

### **NOTE:**

*Only Channels 0 and 1 can be set with the table mode.*

8.2 The table mode is toggled on and off by an 'M t' command from the serial port and executes customer provided profile points. 'M 0' always turns off the table and returns to single tone mode. The 409B starts execution of the profile immediately upon a receipt of 'M t' following an 'M 0'.

8.3 The command sequence (**bold**) is of this form (comments after the ';' are not sent to the 409B, but are here for explanation purposes):

```
M 0
    ;turns off running table mode
t0 0000 aabbccdd,eeff,gghh,ii
    ;F0 profile point 0, on output 0
t1 0000 aabbccdd,eeff,gghh,ii
    ;F1 profile point 0, on output 1
t0 0001 aabbccdd,eeff,gghh,ii
    ;F0 profile point 1
t1 0001 aabbccdd,eeff,gghh,ii
    ;F1 profile point 1
...
t0 3fff aabbccdd,eeff,gghh,ii
    ;F0 profile point 0x3fff
t1 3fff aabbccdd,eeff,gghh,ii
    ;F1 profile point 0x3fff
M t
    ;begin execution of table
```

; '0000' two byte RAM address, T0 and T1 must be paired with same address

; 'aabbccdd' four bytes frequency, hexadecimal, MSB first, 4 bytes. 0.1Hz resolution on LSB

; 'eeff' phase offset, hexadecimal, MSB first, only 14-bits active, top two bits are ignored

; 'gghh' amplitude scale, MSB first, only 10-bits active. Amplitude is scaled per above.

; 'ii' dwell time, MSB first, in increments of 100µs. 0x00=loop back to start, 0xff=hold present setting. Each T0-T1 pair must have the same dwell.

8.4 The ',' (comma) in each record is used as a delimiter and must be included as shown. The inputs are not case sensitive. Subsequent 'M t' commands will toggle the execution of the table on and off. Upon execution of the table, the output will always begin with address 0000 and progress until it encounters an 0xff or 0x00 in a dwell position. The last record in a table mode will be executed for 100µs if the dwell is set to 00.

### **NOTE:**

*Each record must be terminated with an 0x00 or 0xff in the dwell position to indicate the end of your data.*

8.5 The current values stored in RAM can be read back by the "Dn aaaa" command. N=0 or 1 and "aaaa" is the address.

8.6 The RAM table is backed-up by a "supercap" for a minimum of 10 minutes. This allows for short power interrupts without losing the table information. (Consult factory for battery backup options).

8.7 **Other Modes.** The 409B can be programmed by using the "B" command to perform many other outputs. The "B" command can be used to gain control over the on-board AD9959 DDS ASIC. Refer to the Analog Device data sheet for detailed information when using the "B" command.

8.8 See AN003 for the Model 409B/01 which includes a variable pulse width (variable symmetry) output option.

## 9.0 Appendix B. External Reference Option.

9.1 The /R option converts the external clock input to a 10.00 MHz reference input (consult factory for 5.00 MHz). This option provides locking and tracking circuitry to generate an exact binary clock needed to allow even output steps.

9.2 The external clock input on the 409B series is changed to accept 10.00 MHz. A reference input signal is automatically detected and, if within a lock range of approximately  $\pm 5$ ppm, it is locked to and tracked by the narrow-band phase lock loop.

9.3 If an input signal is not detected, the unit will default to the internal free-running oscillator and perform identically to a 409B without the /R option.

9.4 The front panel LED will display four conditions:

**Steady Green:** unit is locked to a stable reference, or is using the free running clock.

**Blinking Green:** unit is stabilizing to a free running condition. This occurs upon power-up or if the reference is removed.

**Steady Red:** unit detects an external input, but cannot lock to it.

**Blinking Red:** unit has detected a change in the reference and is attempting to lock. This will occur if a reference is applied to a unit that has been free running.

9.5 When changing the reference mode, the phase lock loop may take several minutes to stabilize to the final resolution of the 409B. Changing from a blinking LED to a stable LED indicates that the process is completing, but you should verify the outputs.

9.6 The /R option diverts the external clock line so the "C E" command is no longer valid. The "Kp" command should not be used. If either command is used with the /R option, you will get unpredictable behavior.

# WARRANTY

NOVATECH INSTRUMENTS, INC. warrants that all instruments it manufactures are free from defects in material and workmanship and agrees to replace or repair any instrument found defective during a period of one year from date of shipment to original purchaser.

This warranty is limited to replacing or repairing defective instruments that have been returned by purchaser, at the purchaser's expense, to NOVATECH INSTRUMENTS, INC. and that have not been subjected to misuse, neglect, improper installation, repair alteration or accident. NOVATECH INSTRUMENTS, INC. shall have the sole right to final determination regarding the existence and cause of a defect.

This warranty is in lieu of any other warranty, either expressed or implied, including but not limited to any warranty of merchantability or fitness for a particular purpose. In no event shall seller be liable for collateral or consequential damages. Some states do not allow limitations or exclusion of consequential damages so this limitation may not apply to you.

All instruments manufactured by NOVATECH INSTRUMENTS, INC. should be inspected as soon as they are received by the purchaser. If an instrument is damaged in shipment the purchaser should immediately file a claim with the transportation company. Any instrument returned to NOVATECH INSTRUMENTS, INC. should be shipped in its original shipping container or other rigid container and supported with adequate shock absorbing material.

This warranty constitutes the full understanding between NOVATECH INSTRUMENTS, INC. and the purchaser and no agreement extending or modifying it will be binding on NOVATECH INSTRUMENTS, INC. unless made in writing and signed by an authorized official of NOVATECH INSTRUMENTS, INC.

## NOVATECH INSTRUMENTS, INC.

P.O. Box 55997  
Seattle, Washington 98155-0997  
United States of America

FAX: 206.363.4367  
TEL: 206.301.8986  
<http://www.novatech-instr.com/>  
[sales@novatech-instr.com](mailto:sales@novatech-instr.com)

Copyright 2007-2012 Novatech Instruments, Inc.