

GANGED TUNER SCROUNGED FROM
OLD TUBE CAR RADIO.
Q≈100 FOR EACH COIL.

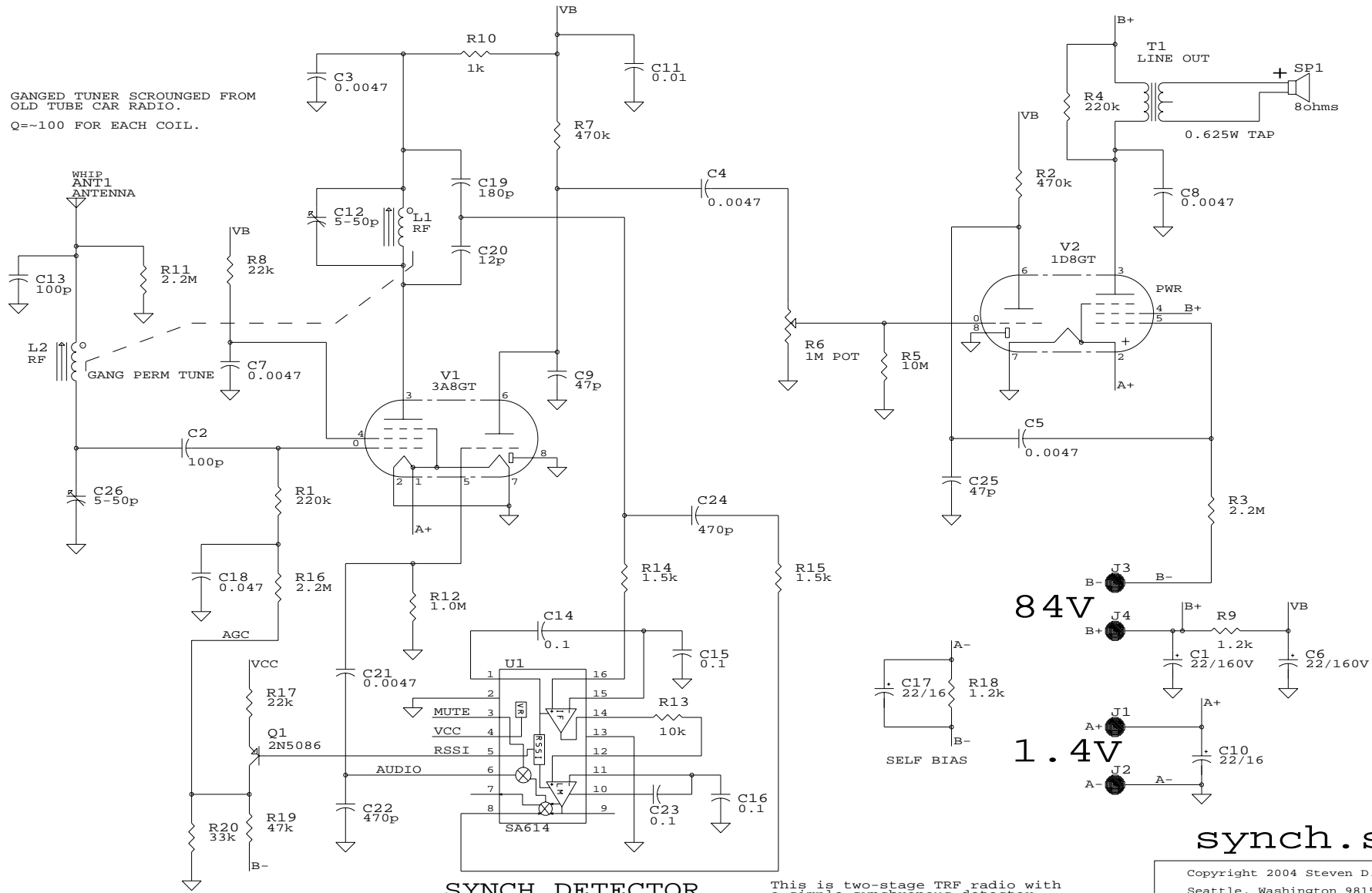

SYNCH DETECTOR

VCC=+5v.

This is two-stage TRF radio with a simple synchronous detector.

An FM radio chip is used for the limiting function and the audio detector.

AGC, Mute and final gains are TBD, but as a breadboard this radio works.

synch.sch

Copyright 2004 Steven D. Swift, P.E. Seattle, Washington 98155 USA		
Proprietary Information		
Title Two Tube Retro Radio (Homodyne).		
Size	Document Number	REV
B		-
Date:	October 15, 2004	Sheet 1 of 1